

Analyze the following Circuits

Arrows represent electron flow



Model A

There is no current because the circuit is not complete.

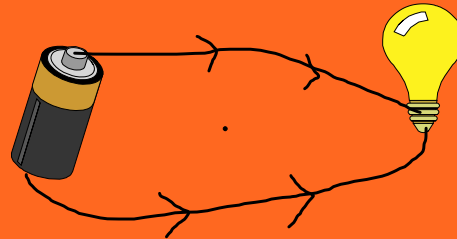

Model B

Current will flow toward the bulb through both wires



Model C

More current flows from the battery to the light and less from the light to the battery.



Model D

Current is the same on both sides of the lightbulb. This is example of the Convention theory of electro flow.

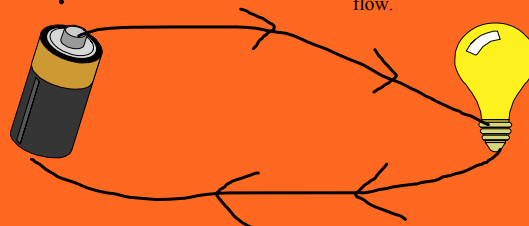

Ohm's Law

Ohm's
Law

$$I = \frac{V}{R}$$

Electric current = Voltage / Resistance

OHM'S LAW FOR DC CIRCUITS

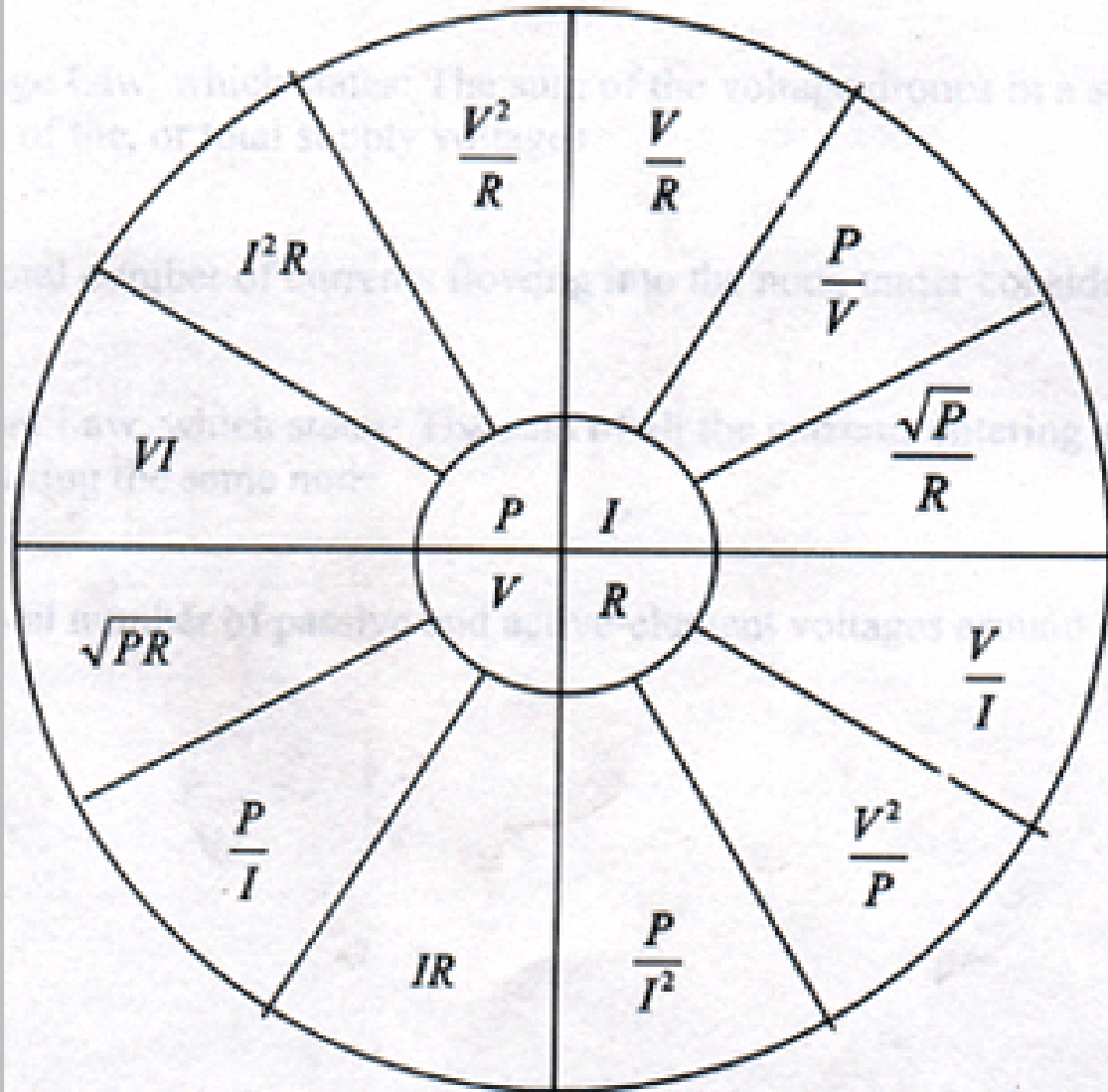

p= power (watts)

I= current (Amps)

V(E) = Voltage (volts)

R = Resistance (Ohms)

Electric potential diagram

Circuit A

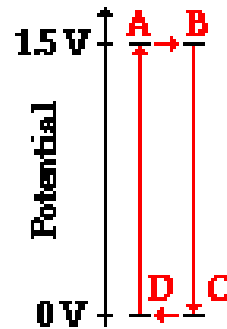
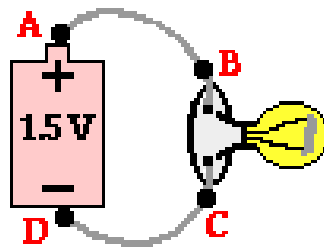

Circuit B

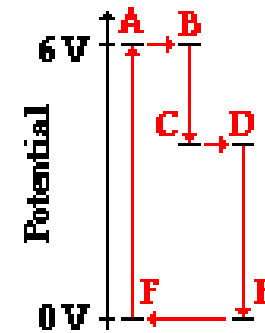
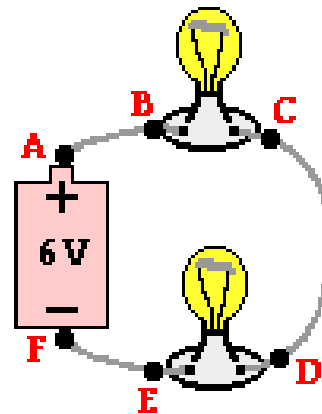

Series Circuit

Voltage

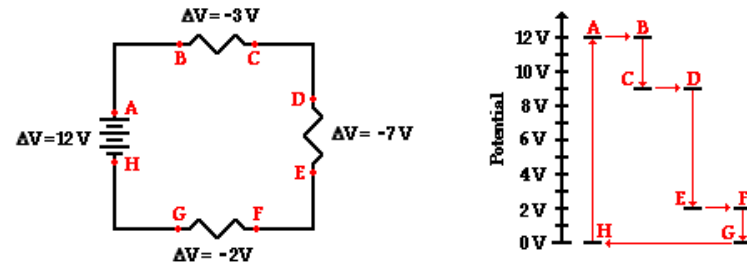

Resistance

Equivalent Resistance

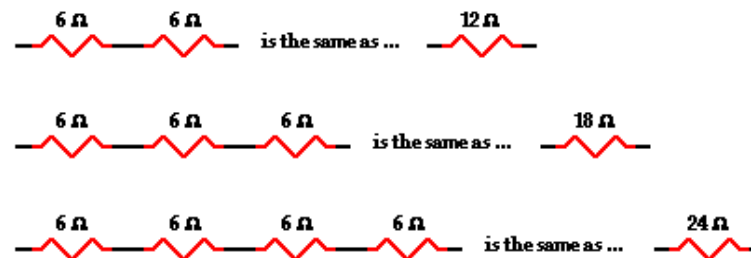

Current

$$I_{\text{battery}} = I_1 = I_2 = I_3 = \dots$$

Mathematical Ohm's Law series

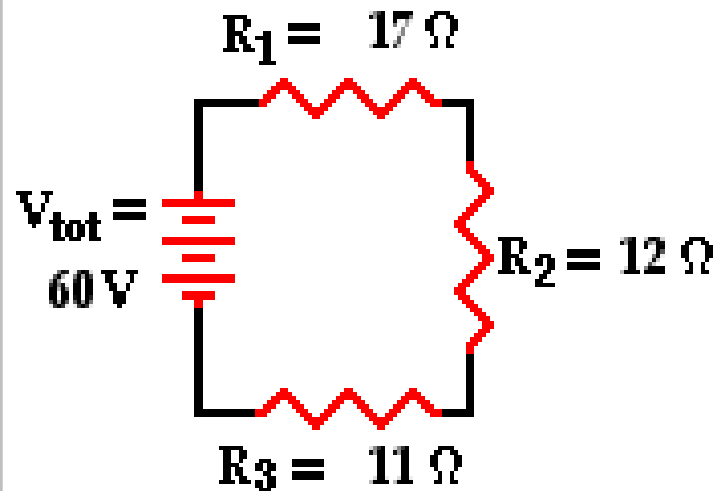

$$R_{\text{eq}} = \boxed{}\ \Omega$$

$$I_{\text{tot}} = \boxed{}\ \text{A}$$

$$I_1 = \boxed{}\ \text{A}$$

$$V_1 = \boxed{}\ \text{V}$$

$$I_2 = \boxed{}\ \text{A}$$

$$V_2 = \boxed{}\ \text{V}$$

$$I_3 = \boxed{}\ \text{A}$$

$$V_3 = \boxed{}\ \text{V}$$

question bank

<http://www.glenbrook.k12.il.us/gbssci/phys/Class/circuits/u9l4c.html>



Parallel Circuits

Amps

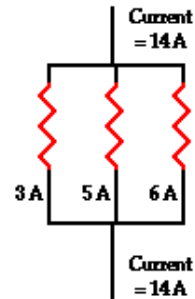

The current outside the branches is equal to the sum of the current values in the branches.

In equation form, this principle can be written as

$$I_{\text{total}} = I_1 + I_2 + I_3 + \dots$$

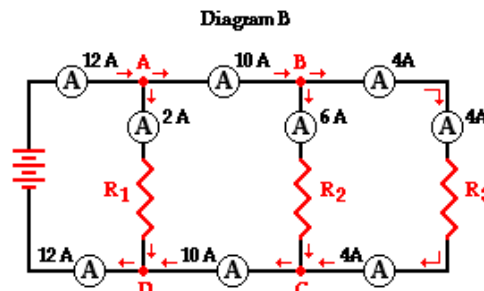
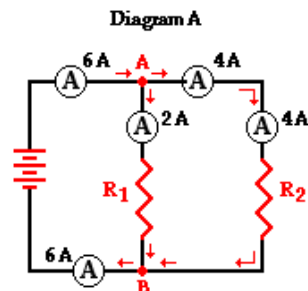

Equivalent Resistance

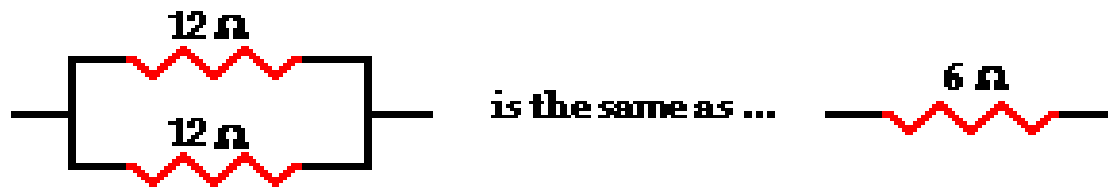
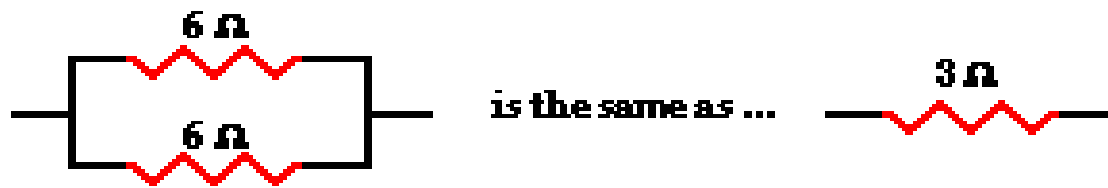
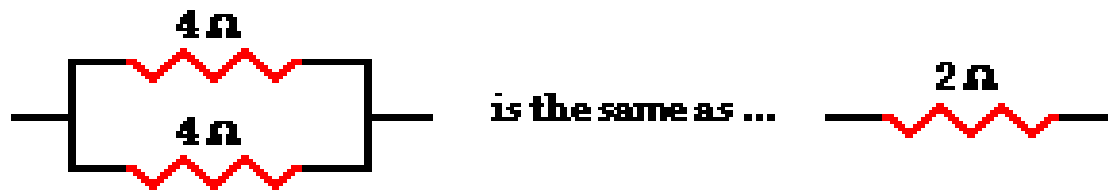

Voltage

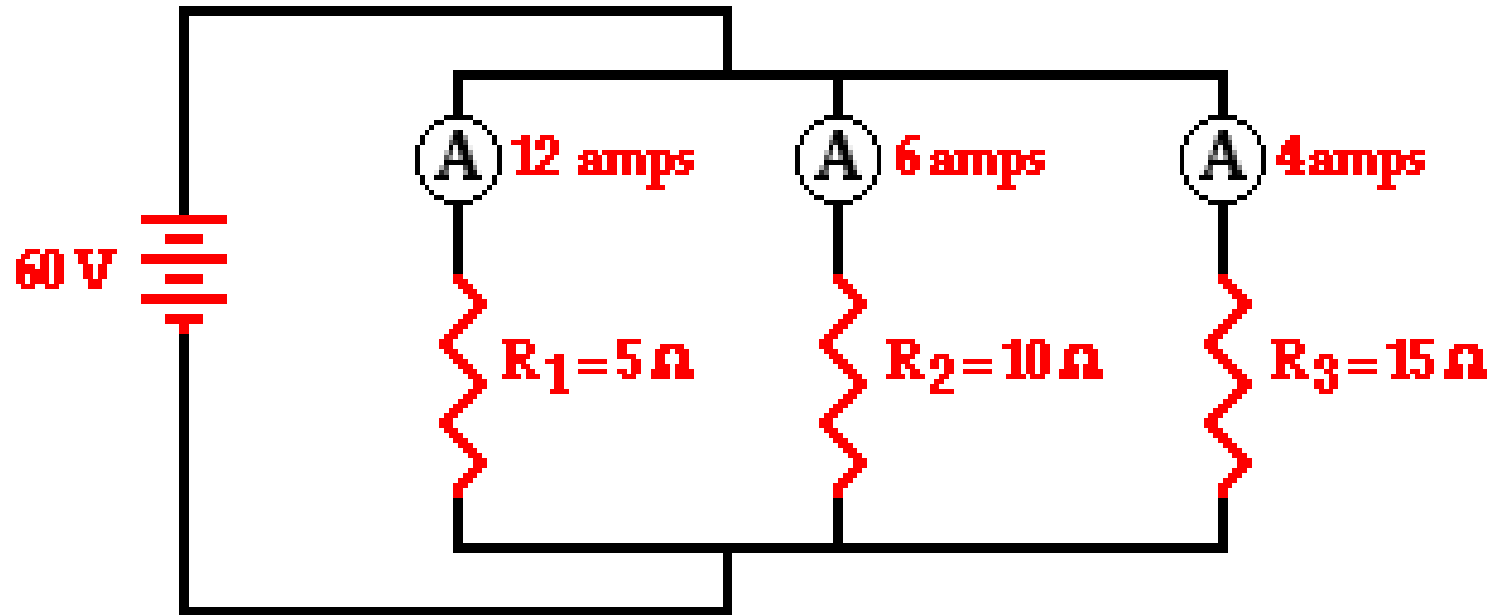

Mathematical Analysis parallel

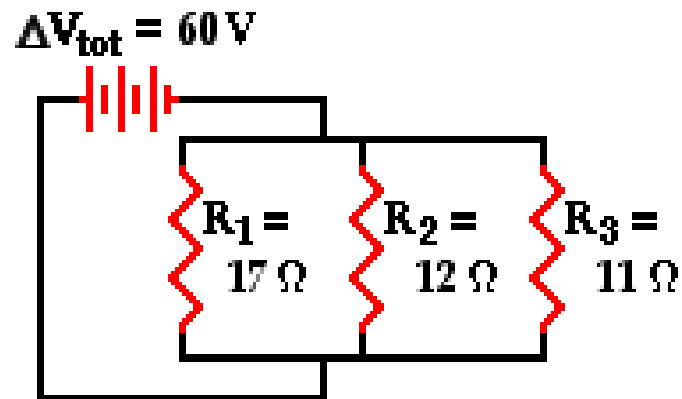

$$R_{\text{eq}} = \boxed{} \Omega \quad I_{\text{tot}} = \boxed{} \text{ A}$$

$$I_1 = \boxed{} \text{ A} \quad V_1 = \boxed{} \text{ V}$$

$$I_2 = \boxed{} \text{ A} \quad V_2 = \boxed{} \text{ V}$$

$$I_3 = \boxed{} \text{ A} \quad V_3 = \boxed{} \text{ V}$$

Summary

Series Circuits

- The current is the same in every resistor, this current is equal to that in the battery.
- The sum of the voltage drops across the individual resistors is equal to the voltage rating of the battery.
- The overall resistance of the collection of resistors is equal to the sum of the individual resistance values,

$$R_{\text{tot}} = R_1 + R_2 + R_3 + \dots$$

Parallel Circuits

- The voltage drop is the same across each parallel branch.
- The sum of the current in each individual branch is equal to the current outside the branches.
- The equivalent or total resistance of the collection of resistors is given by the equation

$$\frac{1}{R_{\text{eq}}} = \frac{1}{R_1} + \frac{1}{R_2} + \frac{1}{R_3} \dots$$

Combination Circuits

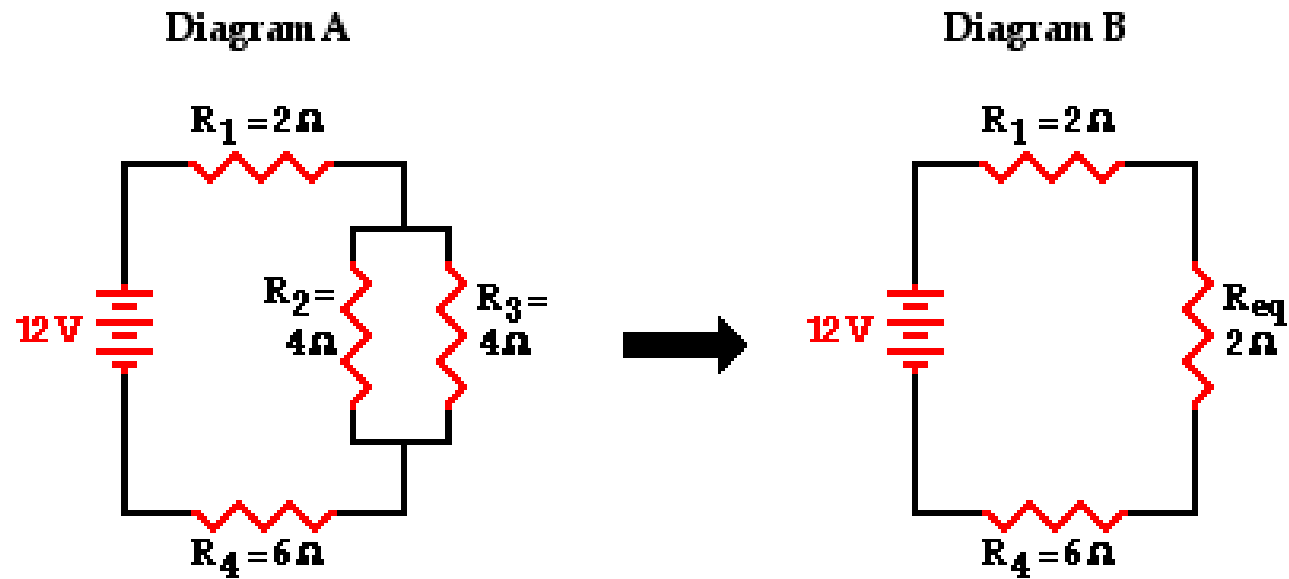

Mathematical Combination

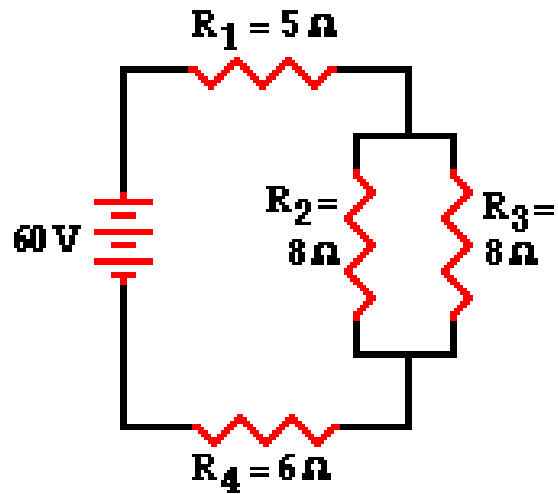

$$R_{\text{tot}} = \underline{\hspace{2cm}}$$

$$I_{\text{tot}} = \underline{\hspace{2cm}}$$

$$I_1 = \underline{\hspace{2cm}}$$

$$\Delta V_1 = \underline{\hspace{2cm}}$$

$$I_2 = \underline{\hspace{2cm}}$$

$$\Delta V_2 = \underline{\hspace{2cm}}$$

$$I_3 = \underline{\hspace{2cm}}$$

$$\Delta V_3 = \underline{\hspace{2cm}}$$

$$I_4 = \underline{\hspace{2cm}}$$

$$\Delta V_4 = \underline{\hspace{2cm}}$$